

Heat Flux Condensation on Coconut Shell Activated Charcoal Porous Media

D. H. Praswanto¹, M. Asroni², T. Priyasmanu³, T. N. Prihatmi⁴

^{1,2,4}Department of Mechanical Engineering, National Institute of Technology Malang, Malang, Indonesia

³Department of Industrial Engineering, National Institute of Technology Malang, Malang, Indonesia

Email: ¹djoko@lecturer.itn.ac.id

ABSTRACT

One way to keep the air humidity is by increasing the heat transfer with the porous media model. Increasing heat transfer depends on the value of the heat flux on the porous media. The heat flux value can be determined by inserting the porous media into the test section and then flow the vapor. The amount of heat absorbed is influenced by the large diameter of the porous on the media used. Therefore, this study aimed to optimize coconut shell charcoal by activating the charcoal. The purpose of activating coconut shell charcoal is to enlarge the pores so that it absorbs heat better than charcoal that has not been activated. The research method used is an experimental method and compares the results of research with previous studies. The porous media was vaporized for 60 minutes with a vapor temperature of 30 °C, while the vapor speed was varied, namely 1 m/s, 2m/s and 3 m/s. From the research results, that by using coconut shell activated charcoal, the heat flux value was higher than using coconut shell charcoal media. This is because the pore size in activated charcoal is larger and more numerous than charcoal that has not been activated so that it absorbs more heat. In addition, the greater the vapor speed, the higher the heat flux, because in the test section more vapor enters than vapor that comes out so that the porous media has a long time to absorb heat in the vapor. The heat transfer that occurs in porous media includes forced convection heat transfer because it has a value of $Gr/Re2 < 1$.

Keywords: Heat Flux, Porous Media, Coconut Shell Activated Charcoal, Convection Heat Transfer

Paper type Research paper

INTRODUCTION

In everyday life, things related to humidity are often encountered. Air humidity is the amount of water vapor contained in the air. In general, air humidity is influenced by air temperature. So that the lower the air temperature, the more water vapors is contained in the air [1]. If the air temperature is below the saturated vapor temperature (vapor saturated) with a pressure of 1 atmosphere (atm) there will be a phase change, from the vapor phase to the liquid phase or it is called a condensation event [2]. Initially, condensation occurs in the form of grains that stick to the surface wall (dropwise). Of the many grains that stick to the surface wall, they will be connected to each other to form a condensation layer on the surface wall (filmwise). Condensation can be divided into two, namely surface condensation and capillary condensation. Surface condensation occurs on surface walls, whereas capillary condensation occurs on surface pores. This capillary condensation or micro-condensation occurs on the porous surface walls [3, 4].

To minimize the occurrence of condensation, the porous media are used. The greater the ability of the media to absorb water, the less condensate will stick to the surface walls [5]. This mechanism occurs because of the Van Der Waals force that is the attractive force between molecules, atoms or ions [6]. In this research, the condensation on porous media used was activated charcoal. The use of activated charcoal was based on the structure of the activated charcoal. Activated charcoal has bigger pores because in the activation process it chemically binds the impurities that cover the pores [7, 8, 9].

The purpose of the condensation on the porous media is be used to control humidity. In addition to using a material that easily absorbs water on the surface wall, controlling humidity can also increase heat transfer [10]. This is because by increasing heat transfer, the air temperature can increase so that the amount of water vapor contained in the air is small. In general, to increase heat transfer, one of them is by expanding the area of the heat transfer surface (extended surface) [11]. During its development, to improve heat transfer a new model with the same function was developed, namely porous media [12]. Porous media has a porosity that can be passed by fluid flow. By having porosity in it so that the surface area of heat transfers is greater than that of solid objects (massive - solid). In porous media, there are two heat transfers that occur, namely, conduction heat transfer and convection heat transfer where conduction heat transfer is the heat transfer that occurs without moving the mass of the substance, while convection heat transfer is the heat transfer that occurs by moving the mass of the substance [13].

In previous studies, heat transfer on porous media with random porosity in laminar flow using the Kinderman - Ramage method showed that porous media with greater porosity can provide greater heat transfer as well. This was

because with greater porosity, the flow was able to move more freely through the cavities in the porous media. Then this research was developed with porous media in the same flow model to determine the effect of ambient temperature treatment on the dynamic flow of condensate lateral migration with different humidity. But to get laminar flow in the heat transfer experiment on porous media was difficult to obtain, because in the porous media chamber design in the inlet area had different diameters [14]. As there was a sudden enlargement of the diameter, the flow moved irregularly. The speed of the incoming air to the temperature distribution of the porous media was very influencing. With the greater the intake air velocity, the higher the temperature distribution of the porous media. The heat transfer rate was greatest on the porous media near the inlet [15]. As for there was a sudden enlargement in the porous media in the inlet area, a jet of air was formed so that in that area the fluid flow had not been fully distributed to the porous media. However, by increasing the speed of the incoming air, it can cause a vortex on the porous media so that the smaller the mass of the porous media, the bigger the vortex occurred. To keep the intake air temperature distribution more evenly distributed and avoid vortices, it was necessary to add a flow conditioner to the inlet chamber of the porous media. In addition, by adding a flow conditioner, it was easier to get the laminar flow of air into after passing sudden enlargement.

Referring to previous research, this study used porous coconut shell activated charcoal as media. The purpose was to activate charcoal to open the pores in coconut shell charcoal so that it can absorb more condensate. Therefore, coconut shell activated charcoal was able to maintain air humidity. The results of this study will be compared with previous studies using porous coconut shell charcoal media. Heat flux on porous media of coconut shell charcoal can be shown in Figure 1.

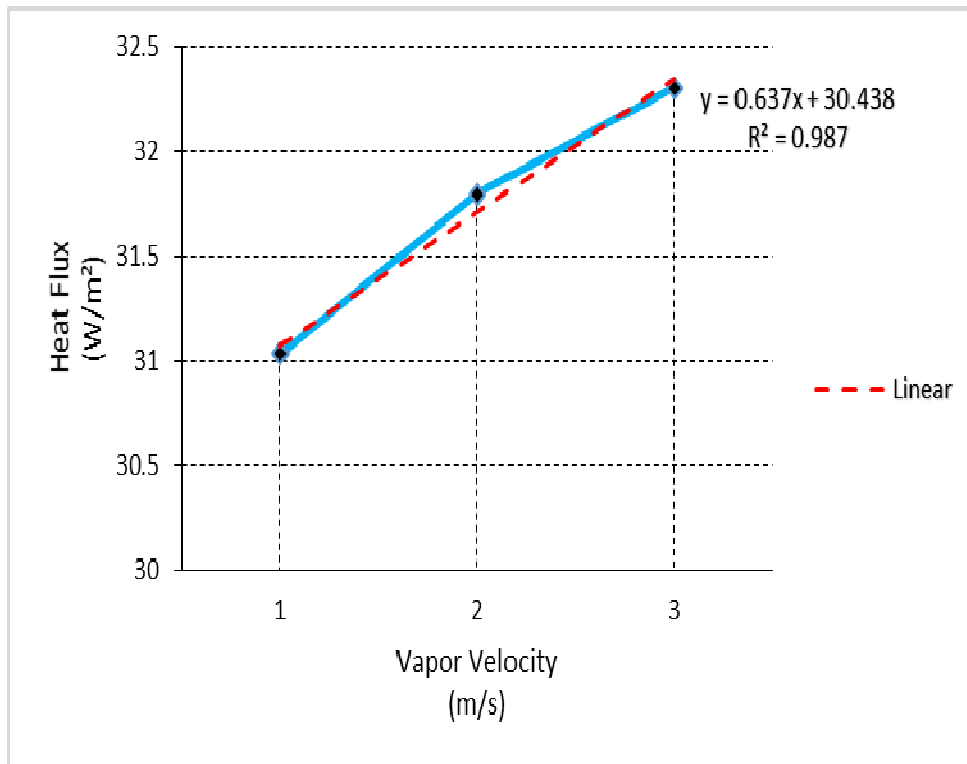

Fig 1. Vapor velocity on heat flux porous media of coconut shell charcoal [16]

In Figure 1 above, the change in the velocity of the inlet vapor, the higher the heat flux value on the porous media. This was because the higher the vapor velocity had a high effective thermal conductivity value so that the heat flux value increased as the heat flux value was influenced by the amount of effective thermal conductivity [16].

METHOD

The method used in this study was experimental methods, where direct observation was to find the cause and effect of the phenomena that occur. In this study, the porous media used was coconut shell activated charcoal. This porous media was put into the test section, then vapor was applied over the porous media with a temperature of 30 ° C for 60 minutes. The velocity of the incoming vapor was varied, namely 1 m/s, 2 m/s dan 3 m/s.

The research tools used in this research were compressor, heater, humidifier tank, cooling machine and data logger which were assembled as shown in Figure 2.

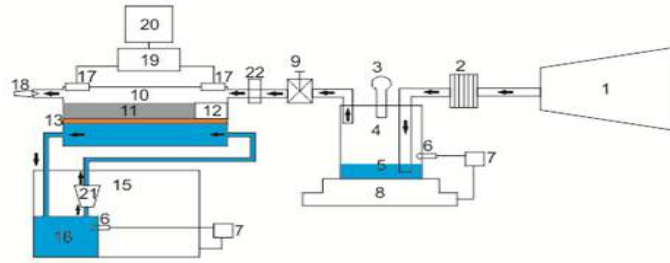

Fig 2. Research Tools Design

Information:

- | | |
|--------------------------|-----------------------------|
| 1. Compressor | 12. Step (Flow Conditioner) |
| 2. Air Filter | 13. Copper Plate |
| 3. Pressure Gauge | 14. Cold Water Room |
| 4. Humidifier tank | 15. Cooling Machine |
| 5. Water | 16. Cold Water |
| 6. Thermocouple | 17. Humidity sensor |
| 7. Thermocontrol | 18. Pitot Tube |
| 8. Heater | 19. Data Logger |
| 9. Regulator | 20. Monitor |
| 10. Condensation Chamber | 21. Cold Water Pump |
| 11. Activated Charcoal | 22. 11. Flow Meter |

In Figure 2, the procedure started from filling water into the humidifier tank, then turning on the compressor to apply pressure to the humidifier tank. The air from the compressor flowed into the humidifier tank through the air filter so that the water contained in the air from the compressor was filtered. Simultaneously with starting the compressor, the heater was turned on to a temperature of 30 ° C. To keep the temperature constant, the heater was equipped with a thermo control that turned off the heater automatically according to the temperature set up. In addition, the cooling engine which had been filled with water was turned on to a temperature of 10° C. Next, the test section was prepared by filling the porous media with activated coconut shell charcoal in the test section and installing a thermocouple to see the temperature on the porous media. After that, turned on the data logger and connected to the monitor. When the vapor temperature reached 30° C and the cold water temperature was 10° C, the cold water pump was turned on to drain cold water and the regulator was opened and adjusted the speed according to variations with the flow meter. The direction of flow of vapor and cold water was in accordance with the direction of the arrow in Figure 3.

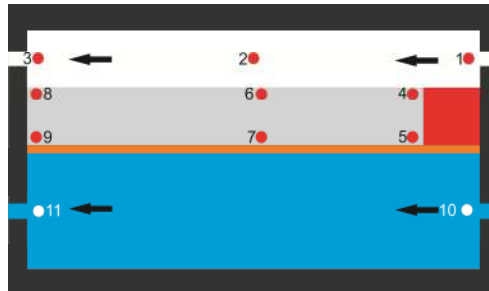

Fig 3. Thermocouple gauge position and flow direction

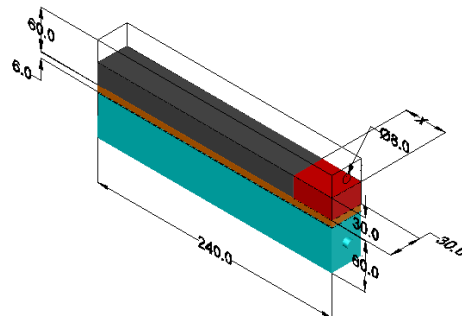

Fig 4. Test Section Design

Figure 4 was the test section design that had a width of 30 mm, a length of 240 mm and a height of 60 mm. The red color in the figure was a step that functions as a condition for the incoming vapor with various lengths. For gray color, it was porous activated charcoal media with a length corresponding to the length of the test section minus the step length. Above porous media and step were empty spaces which will be flowed by vapor. In porous media, the step and the vapor space were called the condensation space. As for the blue color, it was a cold water flow chamber which had a length of 240 mm, a width of 30 mm and a height of 30 mm. Between the condensation room and the cold water room, there was a yellow copper plate that functioned as a heat exchanger with a plate thickness of 5 mm.

After that, the observation of the phenomenon of condensate absorption by porous media was carried out in the test section and a monitor connected to the data logger to see the changes in temperature. After obtaining the test data, next step was to calculate the effective thermal conductivity, heat flux, Reynold Number, and Grashof number.

In calculating heat flux, the equation 1 below was used.

$$q'' = K \cdot \frac{T_1 - T_2}{Z} \quad (1)$$

Information:

k = Thermal conductivity (W/m.°C)

T₁ = Initial temperature (°C)

T₂ = Final temperature (°C)

Z = Condensate thickness

Because there are 2 different thermal conductivities, namely the thermal conductivity of porous media filled with water and thermal conductivity of air filled, the thermal conductivity used in equation 1 above used effective thermal conductivity as in equation 2.

$$K_{eff} = \frac{k' \cdot k'' \cdot Z}{[k'' \cdot \delta + (1 - \delta)]} \quad (2)$$

$$k' = \left\{ \left(1 - \varepsilon^{\frac{2}{3}} \right) + \frac{\varepsilon^{\frac{2}{3}}}{\left(1 - \varepsilon^{\frac{1}{3}} \right) + \varepsilon^{\frac{1}{3}} \left(\frac{k_p}{k_L} \right)} \right\} k_p \quad (3)$$

$$k'' = \left\{ \left(1 - \varepsilon^{\frac{2}{3}} \right) + \frac{\varepsilon^{\frac{2}{3}}}{\left(1 - \varepsilon^{\frac{1}{3}} \right) + \varepsilon^{\frac{1}{3}} \left(\frac{k_p}{k_a} \right)} \right\} k_p \quad (4)$$

Information:

K_{eff} = Overall effective thermal conductivity on the porous media layer

K' = the thermal conductivity of the porous media with condensate

K'' = the thermal conductivity of the porous media

Z = thickness of porous media

Δ = Thickness of Condensate

ε = Porosity

k_p = thermal conductivity of particles

k_L = Thermal condensate

k_a = thermal conductivity of air

L = surface area of the media

To find out the type of laminar flow, transition, turbulence or chaos at the vapor in the test section, the calculation done by using the Reynold Number as in equation 5.

$$Re = \frac{\rho \cdot v_s \cdot D}{\mu} = \frac{v_s \cdot D}{\nu} \quad (5)$$

Information:

Re = Reynold Number

ρ = Fluid density (kg/m³)

v_s = Fluid velocity (m/s)

D = Diameter (m)

ν = Kinematic Viscosity (m²/s)

ν = μ/ρ

After finding the heat flux and Reynold Number values, then found out the convective regime that occurred. In determining the convective regime, the comparative equation between Grashof Number and Reynold Number was used as shown in equations 6 and 7.

$$Gr = \frac{L^3 \cdot g \cdot \beta \cdot (\Delta T)}{\nu^2} \quad (6)$$

$$\frac{Gr}{Re^2} = \frac{\text{Laminer Convection Strength}}{(\text{Force Convection Strength})^2} \quad (7)$$

Information:

Gr = Grashof Number

L = Length of media (m)

G = Gravity (m/s^2)

β = Coefficient of expansion (K^{-1})

ΔT = the difference between the top and the lower temperature (K)

ν^2 = Kinematic Viscosity (m^2/s)

Re^2 = Reynold Number

DISCUSSION

A. Effective Thermal Conductivity

From the test data with the variation of the incoming vapor velocity obtained, calculations were carried out using equations 2, 3 and 4 so that a graph of the effect of vapor velocity on thermal conductivity at any time was obtained as shown in Figure 5

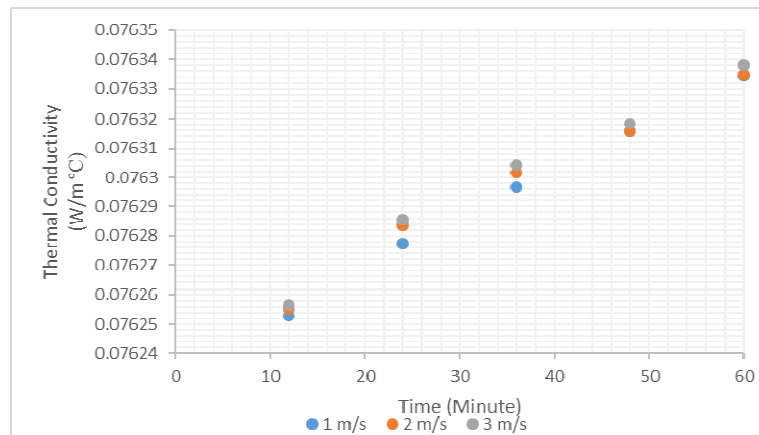

Fig 5. Graph of incoming vapor velocity against effective thermal conductivity

Based on Figure 5 above, in general the effective thermal conductivity (K_{eff}) towards time (t), showed that the longer time used, the more increase in K_{eff} . This was because in equation 2, the calculation of the effective thermal conductivity was influenced by the thickness of the condensate absorbed by the porous media. It meant that the longer it was used, the more water vapor contained in the test section intake stream absorbed by the porous media.

The rate of vapor entry also affected the value of the effective thermal conductivity as shown in Figure 5 above. The higher the vapor speed the greater the value of the effective thermal conductivity. The higher the vapor speed caused the vapor to be retained in the test section because there was a sudden contraction at the outlet of the test section. The outflow of vapor was less than the incoming vapor flow. Therefore, the vapor was retained in the test section so that it provided an opportunity for the porous media to absorb the water contained in the vapor. With a great number of vapor trapped in the test section, more condensate will be absorbed by the porous media.

With the difference in the thickness of the condensate absorbed by the porous media at each step change, the value of the heat flux can be determined. The thicker the absorbed condensate the higher the heat flux value. This was because the calculation of heat flux was influenced by the value of the effective thermal conductivity.

B. Heat Flux on Porous Media

From the results of the calculation of the effective thermal conductivity data, then calculating the heat flux using equation 1, the effect of vapor speed on heat flux was obtained and shown in Figure 6.

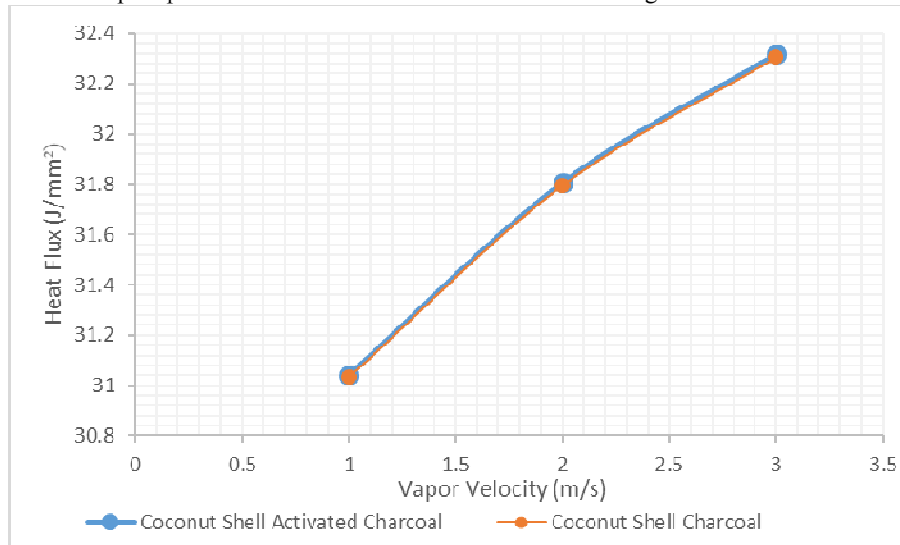

Fig 6. Heat Flux Chart

Judging from the change in the velocity of the vapor inlet, the heat flux value on the porous media was getting higher. In the previous discussion, the higher the vapor speed had a high effective thermal conductivity value so that the heat flux value will increase because the heat flux value was influenced by the amount of effective thermal conductivity. Figure 6 showed the value of heat flux at a speed of 3 m/s was the highest heat flux value. The figure showed that with increasing vapor speed, the heat flux value also increased.

In addition, when compared with porous media of coconut shell charcoal in previous studies, coconut shell activated charcoal had a higher heat flux value. This was influenced by the large pores on the surface of the activated charcoal. Activated charcoal had larger pores than inactivated charcoal as activated charcoal in the activation process opened closed pores. This phenomenon was the reason why activated charcoal was able to absorb more heat than inactivated charcoal.

C. Reynold Number

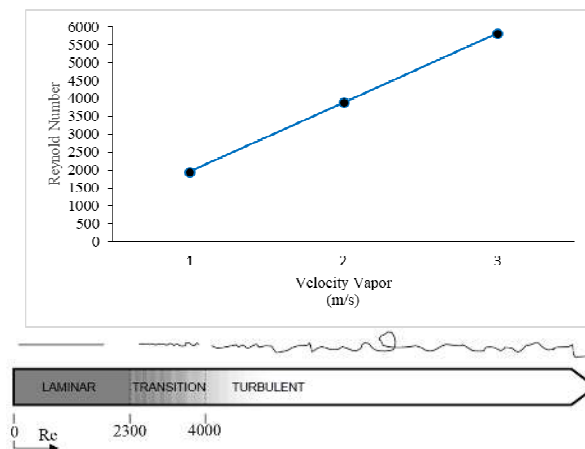

Fig 7. Graph of vapor velocity towards Reynold Number

In Figure 7, there was an increasing trend, the higher the speed the greater the Reynold Number. This was because the Reynold Number was directly proportional to the flow velocity so that with the greater the Reynold Number the shape of the flow occurs, turbulent flow occurs. In this study, with a speed of 3 m/s there was a little vortex in the porous media because at this speed the vapor flow that entered the test section was turbulent. But the higher the vapor entry speed can increase the heat flux value because the higher the entry speed, the more vapor contained in the test section was due to a sudden contraction at the test section outlet so that less vapor comes out of the test section. Therefore, the more condensate was absorbed more and the heat flux value got higher.

D. Convective Regime

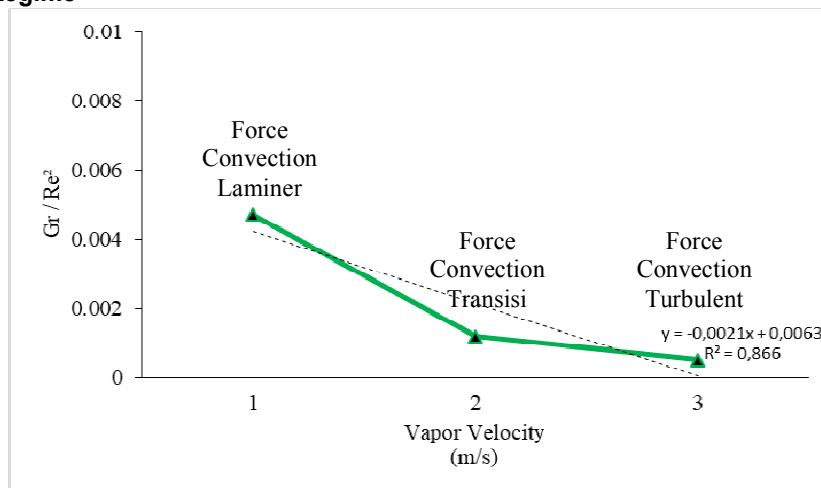

Fig 8. Graph of the effect of speed on Gr/Re^2

In Figure 8 above, there was a decline in trend; this was because with higher speeds it has a large Reynold Number so that the Gr/Re^2 value was small because the Gr/Re^2 value was inversely proportional to the Reynold Number. In the graph above, in general, the convective regime included forced convection. But it had different forced convection, namely, at a speed of 1 m/s laminar forced convection, a speed of 2 m / s transition forced convection and a velocity of 3 m/s turbulent forced convection. This type of forced convection depended on the Reynold number.

CONCLUSION

From this experimental study, it can be concluded that coconut shell activated charcoal is able to absorb more heat than charcoal that has not been activated so that the heat flux value in the porous medium of coconut shell activated charcoal increases. Whereas in the convective regime that occurs, by varying the velocity of the average vapor it is classified as the forced convection regime. For the type of flow that occurs, with increasing vapor speed, the flow becomes more turbulent.

ACKNOWLEDGMENT

We would like to thank the Institute for Research and Community Service (LPPM) of the National Institute of Technology (ITN) Malang for providing research funds so that we can carry out the research and publish the research results.

REFERENCES

- [1] B. Yang, G. Shen, H. Chen, Y. Feng, and L. Wang, "Experimental study of condensation heat-transfer and water-recovery process in a micro-porous ceramic membrane tube bundle," *Appl. Therm. Eng.*, vol. 155, no. February, pp. 354–364, 2019, doi: 10.1016/j.applthermaleng.2019.03.154.
- [2] A. Behrang, P. Mohammadmoradi, S. Taheri, and A. Kantzas, "A theoretical study on the permeability of tight media; Effects of slippage and condensation," *Fuel*, vol. 181, pp. 610–617, 2016, doi: 10.1016/j.fuel.2016.05.048.
- [3] X. Wang, H. Chang, and M. Corradini, "A CFD study of wave influence on film steam condensation in the presence of non-condensable gas," *Nucl. Eng. Des.*, vol. 305, pp. 303–313, 2016, doi: 10.1016/j.nucengdes.2016.06.003.
- [4] M. Kostoglou and T. D. Karapantsios, "Aspects of the Two-Layer Model for Direct Contact Condensation of Steam on Wavy Falling Films," *Chem. Eng. Commun.*, vol. 202, no. 11, pp. 1535–1546, 2015, doi: 10.1080/00986445.2014.958151.
- [5] E. Siswanto, A. Z. Rifan, Purnami, D. Widhiyanuriyawan, and D. B. Darmadi, "The Effect of Porosity on the Temperature Spectrum Area and Heat Transfer in Chamber with Porous Media under the Saturated Vapour Flow," *IOP Conf. Ser. Mater. Sci. Eng.*, vol. 494, no. 1, 2019, doi: 10.1088/1757-899X/494/1/012071.
- [6] M. Ramzan, S. Riasat, S. Kadry, C. Long, Y. Nam, and D. Lu, "Numerical simulation of 3D condensation nanofluid film flow with carbon nanotubes on an inclined rotating disk," *Appl. Sci.*, vol. 10, no. 1, 2020, doi: 10.3390/app10010168.
- [7] M. Sheikholeslami, M. Darzi, and M. K. Sadoughi, "Heat transfer improvement and pressure drop during condensation of refrigerant-based nanofluid; an experimental procedure," *Int. J. Heat Mass Transf.*, vol. 122, pp. 643–650, 2018, doi: 10.1016/j.ijheatmasstransfer.2018.02.015.
- [8] G. Avantaggiato, R. Havenaar, and A. Visconti, "Evaluation of the intestinal absorption of deoxynivalenol and nivalenol by an in vitro gastrointestinal model, and the binding efficacy of activated carbon and other adsorbent materials," *Food Chem. Toxicol.*, vol. 42, no. 5, pp. 817–824, 2004, doi: 10.1016/j.fct.2004.01.004.

- [9] H. Sun *et al.*, "Superhydrophobic activated carbon-coated sponges for separation and absorption," *ChemSusChem*, vol. 6, no. 6, pp. 1057–1062, 2013, doi: 10.1002/cssc.201200979.
- [10] Y. Wang and T. Lu, "Influence of the particle diameter and porosity of packed porous media on the mixing of hot and cold fluids in a T-junction," *Int. J. Heat Mass Transf.*, vol. 84, pp. 680–690, 2015, doi: 10.1016/j.ijheatmasstransfer.2015.01.036.
- [11] M. L. Hwang and Y. T. Yang, "Numerical simulation of turbulent fluid flow and heat transfer characteristics in metallic porous block subjected to a confined slot jet," *Int. J. Therm. Sci.*, vol. 55, pp. 31–39, 2012, doi: 10.1016/j.ijthermalsci.2011.11.008.
- [12] Y. Wang, T. Lu, and K. Wang, "Effect of particle diameter of porous media on flow and heat transfer in a mixing tee," *Ann. Nucl. Energy*, vol. 49, pp. 122–130, 2012, doi: 10.1016/j.anucene.2012.05.031.
- [13] B. Yang, H. Chen, C. Ye, X. Li, and Y. Feng, "Experimental study on differences of heat and mass flux between 10- and 50-nm pore-sized nano-porous ceramic membranes," *J. Aust. Ceram. Soc.*, vol. 55, no. 2, pp. 343–354, 2019, doi: 10.1007/s41779-018-0240-1.
- [14] E. Y. Setyawan, S. Djiwo, and T. Sugiarto, "Simulation Model of Fluid Flow and Temperature Distribution in Porous Media Using Cylindrical, Convergent and Divergent Nozzles," vol. 1, no. 1, pp. 1–10, 2017.
- [15] M. Ramzan, M. Sheikholeslami, M. Saeed, and J. D. Chung, "On the convective heat and zero nanoparticle mass flux conditions in the flow of 3D MHD Couple Stress nanofluid over an exponentially stretched surface," *Sci. Rep.*, vol. 9, no. 1, pp. 1–13, 2019, doi: 10.1038/s41598-018-37267-2.
- [16] D. Praswanto, E. Siswanto, and N. Hamidi, "The effect of step ratio in sudden enlargement channel and vapor's velocity towards condensation heat flux in porous media," *J. Mech. Eng.*, vol. 8, no. 2, pp. 75–82, 2017, doi: 10.21776/ub.jrm.2017.008.02.4.